

# SAFELIFT DAVIT TYPE LD1

All aluminium – lightweight construction.  
Total weight less than 25kg.

- Standard SWL 500kg
- Standard height (H) 1856mm (plus socket height)
- Standard radius (L) 1100, 1300, 1500mm
- Slew 360°
- All aluminium construction
- Lightweight for safe manual handling – total weight of davit 25kg
- Lifting eyes for chain block and slave chain (supplied separately)
- Ideal for lifting submersible pumps, motors, etc.
- Slews easily with minimum manual force, even when fully loaded

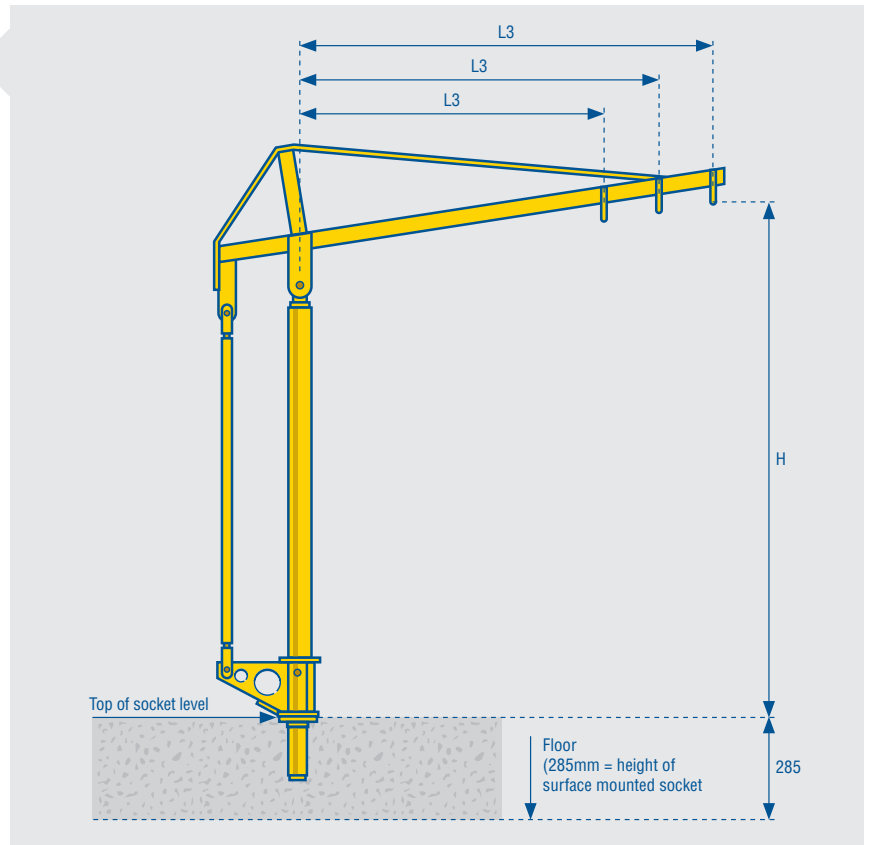

# SURFACE MOUNTED SOCKET SS1

- Standard SWL 500kg
- Fits all Safelift LD1 davits
- Allows easy 360° slew of davit
- Steel construction
- Galvanised finish
- Suitable for floor mounting on concrete or steel floors

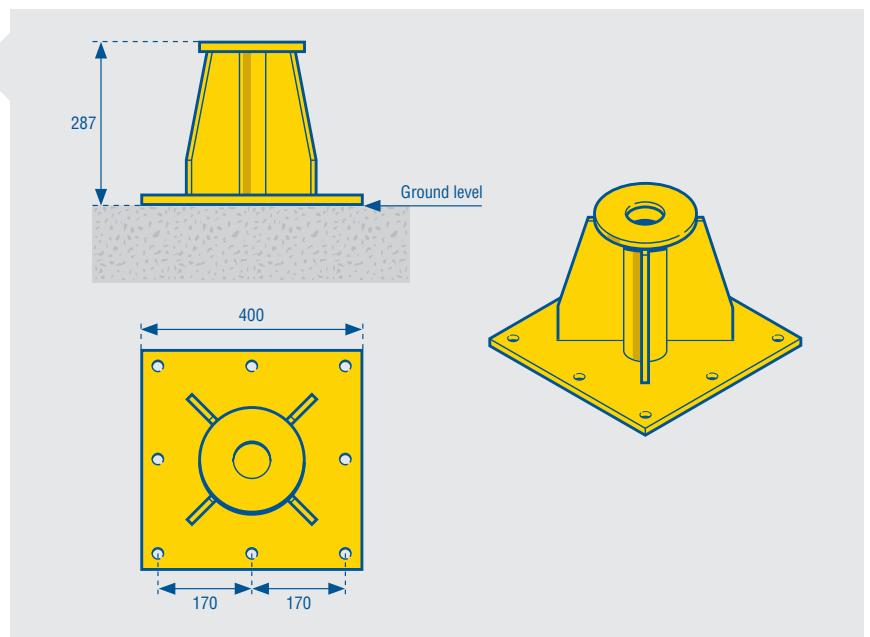

# CAST-IN SOCKET SC1

- Standard SWL 500kg
- Fits all Safelift LD1 davits
- Allows easy 360° slew of davit
- Steel construction
- Untreated finish
- Suitable for casting into new concrete floors

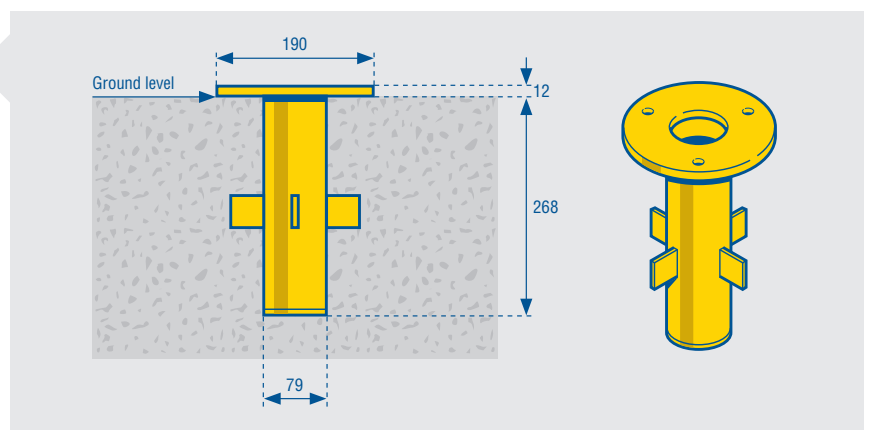

## FLUSH MOUNTED SOCKET SF1

- Standard SWL 500kg
- Fits all Safelift LD1 davits
- Allows easy 360° slew of davit
- Steel construction
- Galvanised finish
- Suitable for floor mounting on steel floors

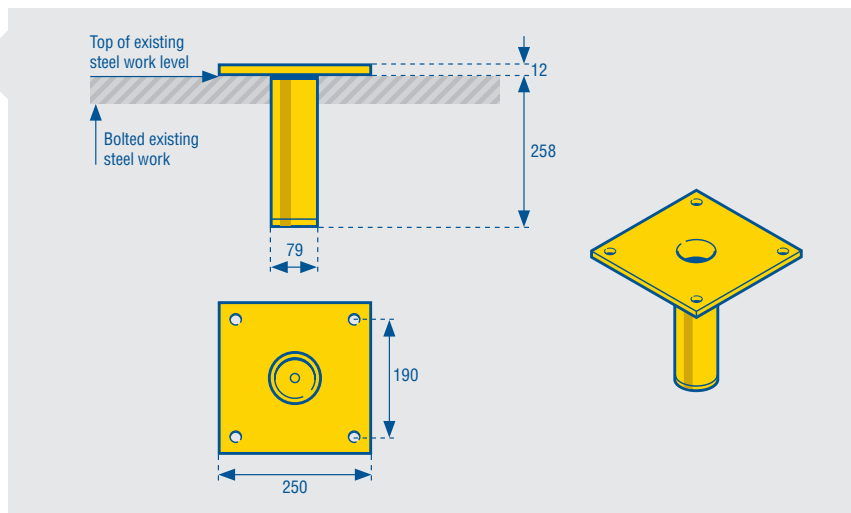

## WALL MOUNTED SOCKET SW1

- Standard SWL 500kg
- Fits all Safelift LD1 davits
- Allows easy 360° slew of davit
- Steel construction
- Galvanised finish
- Suitable for mounting on concrete or steel walls or columns

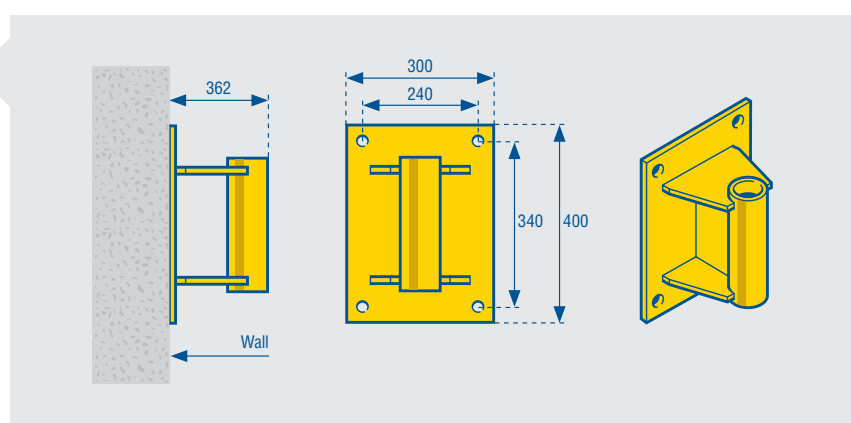

## SAFELIFT 360 HAND CHAIN BLOCK

- SWL 500kg for use with Safelift Davit Type LD1.
- Standard height of lift 3m (other heights available to suit the application).
- Closed height 300mm
- Standard model is steel construction, grade 8 calibrated steel loadchain.
- Corrosion resistant model is zinc plated steel construction with stainless steel loadchain.
- Lightweight for safe manual handling – total weight of chain block with 3m lift is less than 9kg.

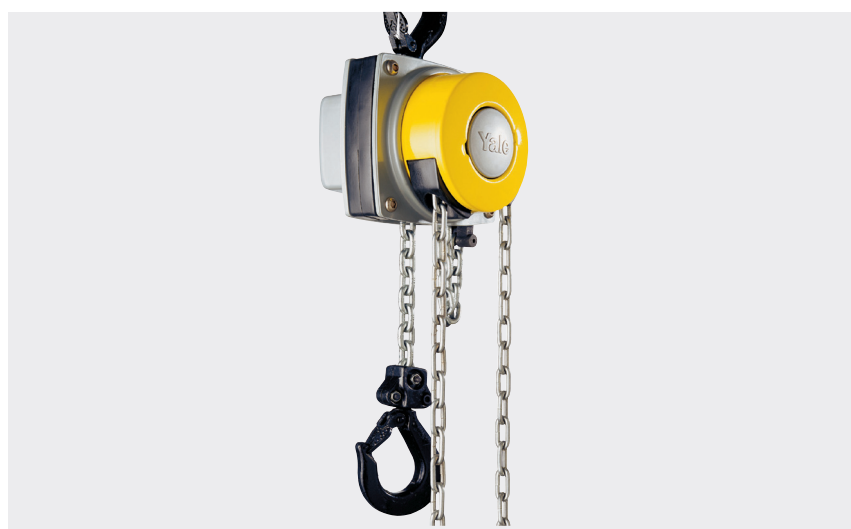

## PUMP LIFTING SLAVE CHAIN PS1

- Standard SWL 500kg
- Fits all Safelift LD1 davits
- Standard length 1m (other lengths available)
- 7mm grade 8, plated lifting chain to EN818
- Tested, CE marked, issued with EC Declaration of Conformity

